

FASTFIX

SCAFFOLDING LTD

SAFE, RELIABLE, FAST



[Fast Fix Scaffolding](#) Ltd is an award winning access provider, operating around Sussex, Surrey and Kent who specialise in the exclusive use of [Layher](#) Allround system scaffolding. Fast Fix has an unprecedented dedication to safety, efficiency and quality of service.

The sole use of the [Layher](#) Allround system, enables us to provide a safer, quicker, and more efficient service to our clients. Our bespoke 'safe erection' procedure ensures our operatives are always prevented from falling at all times, while working at height and fully adheres to the requirements of the Work At Height Regulations 2005.



THE SAFE ERECTION PROCEDURE

[Fast Fix Scaffolding](#) Ltd have developed a procedure for assembling, dismantling, and altering their scaffolds whereby the scaffolder is prevented from a fall at all times. This method uses a combination of collective protection and a restraint harness system. Our methods of work fully adhere to the requirements of the Work at Height Regulations for the use of systems of work which prevent the fall as opposed to systems (fall arrest safety harnesses which is industry practice) which deal with the distance and consequences of a fall. Our methods of work far exceed current industry practice, where fall arrest safety harnesses are relied upon.

THE 'LAYHER ALLROUND' SYSTEM

Due to the multitude of available components and its modular configuration, [Layher](#) Allround scaffolding can vastly reduce assembly times, and labour costs, while greatly increasing safety. [Layher](#) Allround is suitable for use in all forms of scaffolding and is capable of overcoming any intricacy, unlike other forms of system scaffolding. The unique combination of positive and rigid connection in a fast and non-bolted system permits a choice of automatically right-angled, linear or angled connections with built-in safety.

[Layher](#) Allround scaffolding offers an unmatched range of uses, and unbeatably fast assembly, particularly in complex scaffolding applications.

COMMERCIAL

By specialising in the sole use of the [Layher](#) Allround system Fast Fix are able to offer clients huge benefits in terms of time, and financial savings in commercial applications. Highly complex scaffold structures and high level birdcage platforms can be simply and efficiently erected using the versatile [Layher](#) system.

RESIDENTIAL

[Fast Fix Scaffolding](#) Ltd works extensively in the residential sector, and has a client base which includes the majority of the major blue chip house builders, such as Taylor Wimpey, Barratt Developments, Berkeley Homes, Charles Church, and Galliford Try to name a few.

In 2006 Fast Fix won Taylor Woodrow's prestigious national sub-contractor/supplier of the year award for Health and Safety, Innovation and Quality of Service.

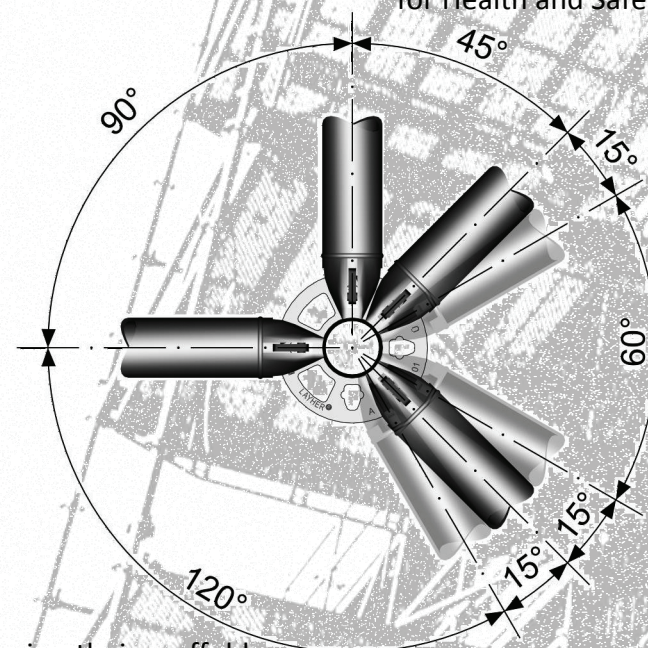

TRAINING & TRADE MEMBERSHIPS

The company is a member of:

- The NASC (National Access and Scaffolding Confederation)
- Construction Line (Fully Vetted Member)
- Building Register (Fully Vetted Member)
- SA-FE (System Access Fall Elimination)

All of our operatives are:

- CSCS Card Holders
- CISRS qualified or enrolled
- [Layher](#) Manufacturers Basic Ticket
- [Layher](#) Manufacturers Advanced Ticket
- Hold a SA-FE safety harness training card

Many are PASMA trained, telescopic and counterbalanced forklift trained, and hold a first aid certificate



Tel: 01293 863 074

Fax: 01293 863 343

Email: info@fastfixscaffolding.com

Web: www.fastfixscaffolding.com

Wrays Farm, Horsehill, Horley, Surrey, RH6 0HN